

PLCBUS2-R 2264HX Two-Load H-Duty Dimmer DIN Module

Main Description:

PLCBUS2-R 2264HX is a Two-Load H-Duty Lamp DIN Module; Each Load can memory 1 main address + 16 Scene Addresses = 17 different addresses. (The Scene Address setup method,

Technical Specs:

Rated Voltage: 230V±10%, 50Hz

Rated Load: Each load not exceeds 1300W for dim;
Two loads not exceed 2000W in sum.

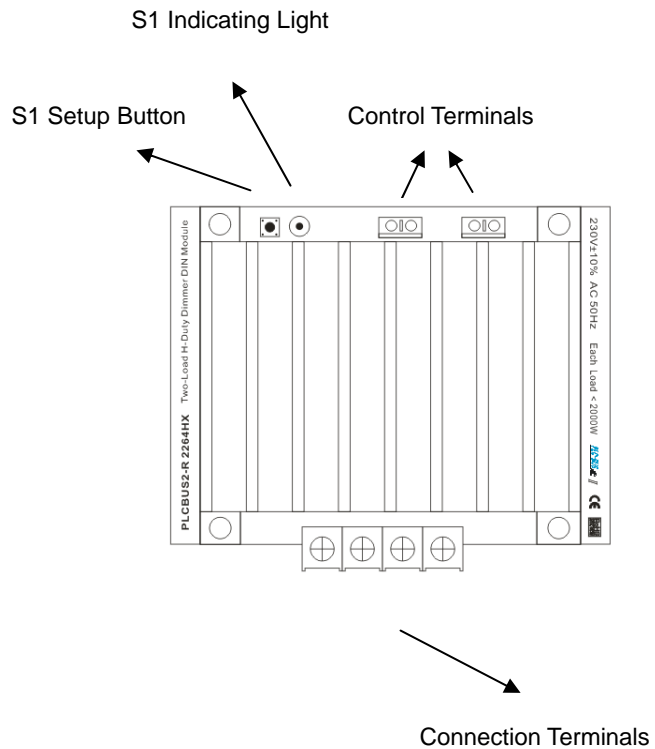

Key Functions:

- (1). S1 is the SETUP key: it can setup 2-load addresses (S1 is for Load1/Load2); If tap S1, you can ON/OFF Load1/2 at the same time.
- (2). Press S1 button and hold for 10 seconds can delete 16 scene addresses of the two loads totally.

Connection Method:

- K1 is connected mechanical switch to local control ON/OFF of Load 1;
- K2 is connected momentary switch (Normal Opened) to local control ON/OFF of Load 1;
- K3 is connected mechanical switch to local control ON/OFF of Load 2;
- K4 is connected momentary switch (Normal Opened) to local control ON/OFF of Load 2;

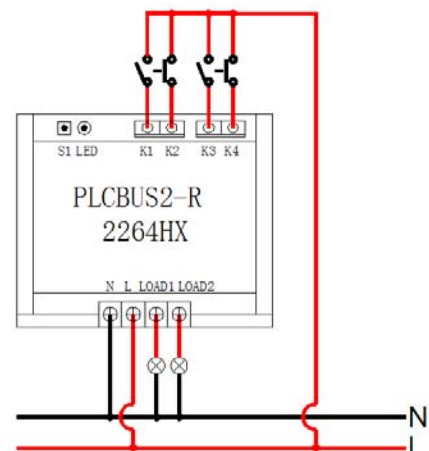

Setup Main Address Method:

- (1). Press S1 key and hold for 5 seconds;
- (2). When the indicating light flickers, releasing, enter setup status;
- (3). Then use #4034 send out a main address to Load1;
- (4). And then #2264HX will enter Load2 address setup status automatically, so you send out the other address, which is the main address for Load2;

Notice: If have no any operation in 10seconds, it will exit setup method automatically.

Installation:

After setup, please fix DIN Module in power distribution box, and stick the lines together will be better;

Notice; the wired into connection columns, please don't use multiplied yarn.